

THE «GREEN», EFFECTIVE TUNNEL-LIFT

CE marked, according to the European directive EN 280

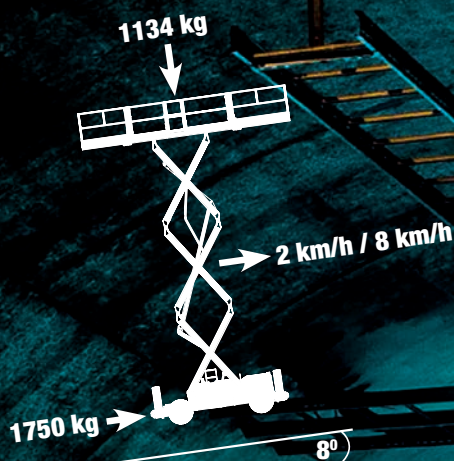

- Driving in height up to 8 degrees slope
- Work legal and more effective
- Hazardous exhaust is reduced to a minimum
- Two batteries and two circuits always give start



HYBEKO

Hybeko Tunnel - 3390 RT

Optional mode controlled by key switch

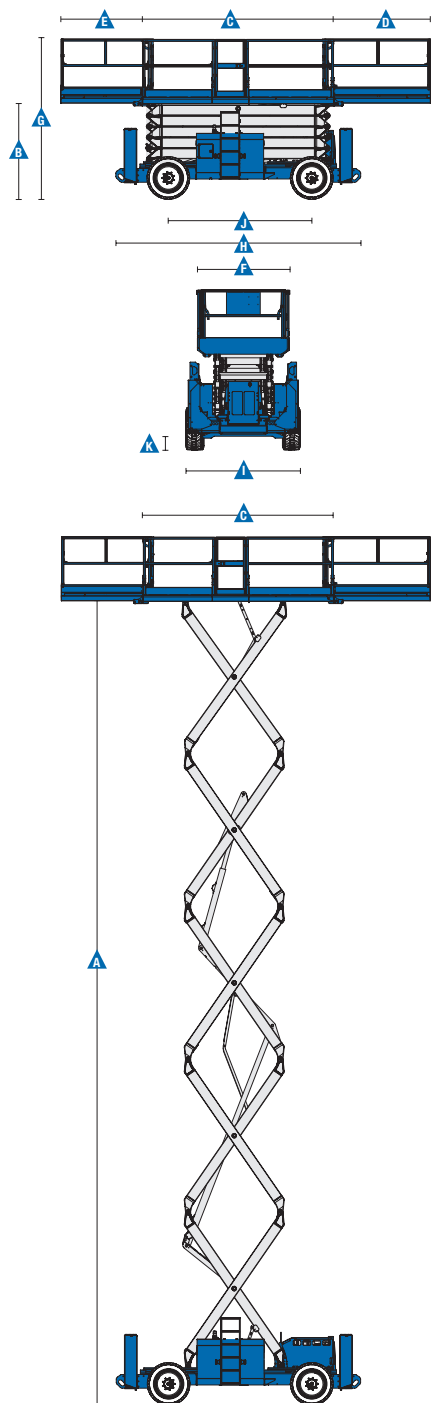

MODELL	Tunnel mode	Standard mode
Working height maximum:	8,00 m	11,94 m
A Platform height maximum:	6,00 m	9,94 m
B Platform height stowed:	1,55 m	1,55 m
C Platform length outside:	3,98 m	3,98 m
D Platform length SuperDeck:	7,38 m	7,38 m
E Slide-out platform extension deck – front:	1,52 m	1,52 m
F Slide-out platform extension deck – back:	1,22 m	1,22 m
G Platform width – outside:	1,83 m	1,83 m
H Height: Stowed	2,71 m	2,71 m
Stowed – rails lowered	2,03 m	2,03 m
I Transport length:	4,88 m	4,88 m
J Transport width:	2,29 m	2,29 m
K Wheelbase:	2,84 m	2,84 m
L Ground clearance - center	0,36 m	0,36 m
Maximum platform occupancy:	7	7
Lift capacity:	1 134 kg	1 134 kg
Drive height:	Max height	Max height
Lift capacity – extension deck:	227 kg	227 kg
Drive speed – stowed:	8,0 km/h	8,0 km/h
Drive speed – platform raised:	2,0 km/h	2,0 km/h
Maximum levelling without outriggers:		
Tunnel mode:	8° (forward/backward), 5° (sideways),	
Standard mode:	3° (forward/backward), 2° (sideways)	
Turning radius – inside:	2,16 m	2,16 m
Turning radius – outside:	5,33 m	5,33 m
Raise / lower speed:	32/19 sec	45/29 sec
Controls:	Proportional	Proportional
Drive:	4WD	4WD
Tires:	Foam filled RT	Foam filled RT
Axle:	Oscillating	Oscillating
Power source:	Deutz D2011L03i	Deutz D2011L03i
Auxiliary Power unit:	12V DC	12V DC
Fuel tank capacity:	113,6 l	113,6 l
Hydraulic system capacity:	113,6 l	113,6 l
*Weight:	6 940 kg	6 940 kg

*Weight will vary depending on options and/or country standards

Exhaust emissions for Hybeko Tunnel lift with Deutz D2011 L031 diesel engine with particle filter/catalyst

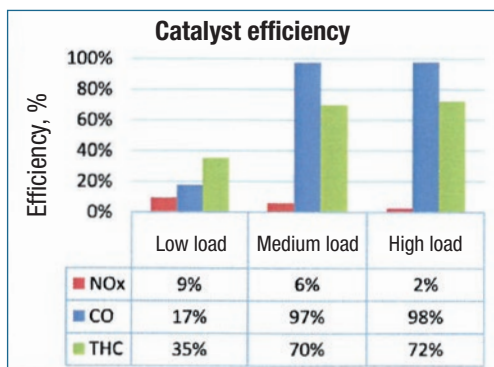

Figure 1: Catalyst efficiency of the reduction of THC, CO and NOx, (%)

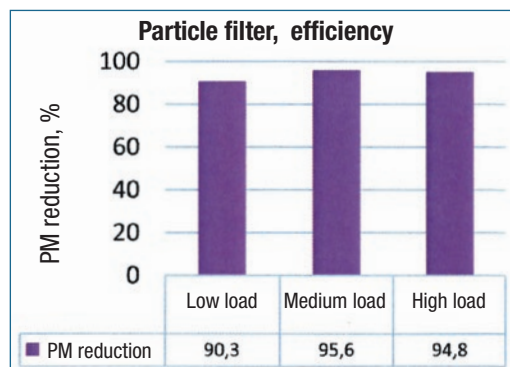
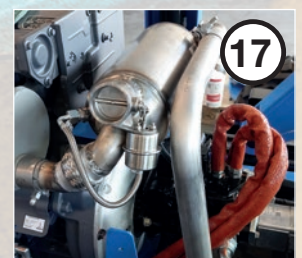
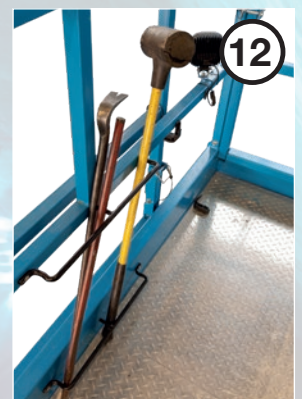
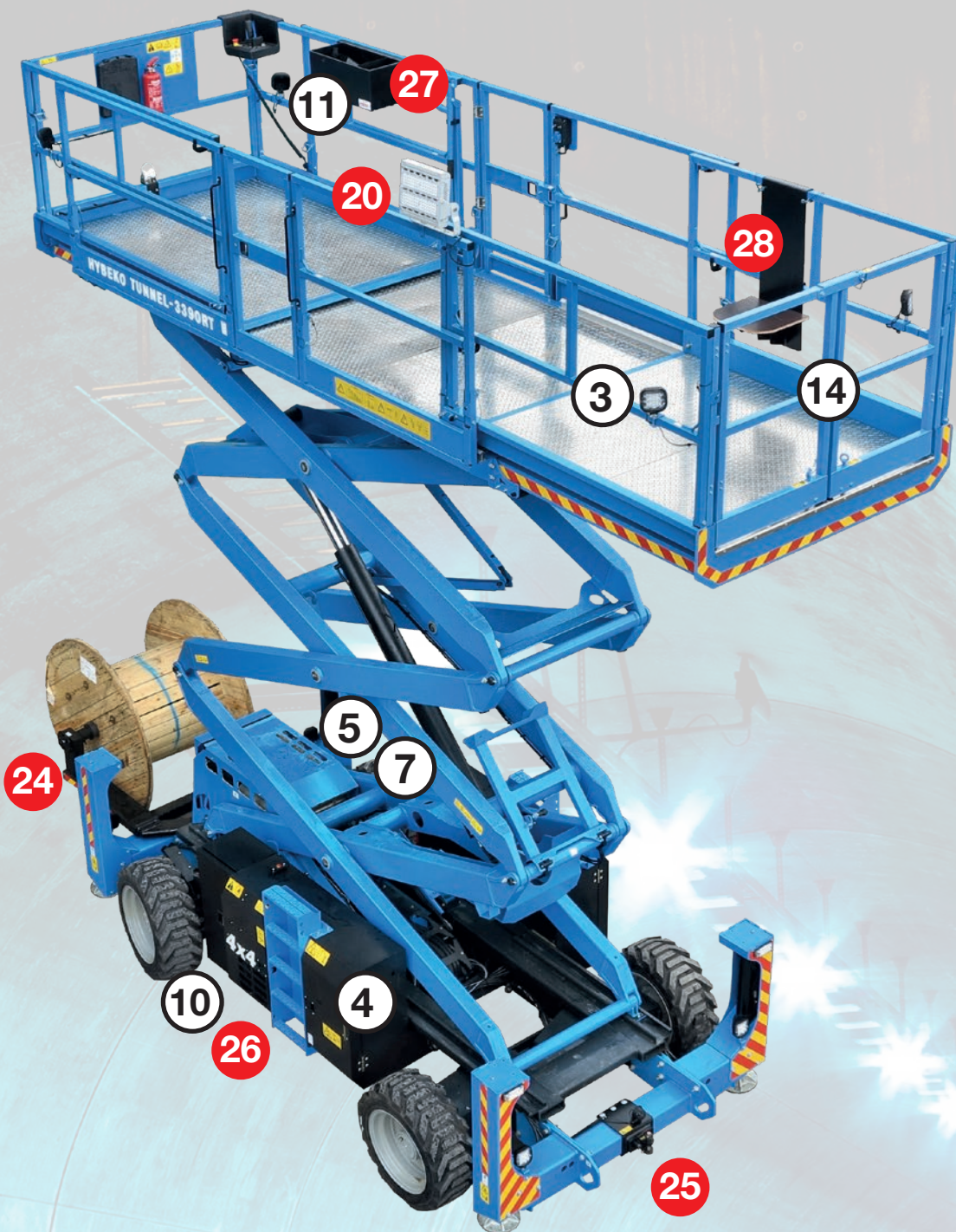

Figure 2: Cleaning efficiency of the particle filter of three load point, (%)



Standard features

- | | |
|--|--|
| 1. Complete set of reflex tape | 11. 1 pcs. toolkit |
| 2. 4 pcs. blitzers mounted on the outriggers | 12. Extra tool holder |
| 3. 4 pcs. LED work light platform | 13. Platform control cover |
| 4. Start battery and extra service battery | 14. Hinged railings for load / unloading |
| 5. Power supply 3.5 kw | 15. Motor heater with 2 battery chargers |
| 6. Extra 230V outlet in platform | 16. Progressive throttle |
| 7. Fire extinguisher in cabinet 6kg | 17. Particle filter with catalyst |
| 8. Fire extinguisher on platform 2 kg | 18. Double air filter |
| 9. Fire blanket | 19. Dinitrol rust treatment |
| 10. 1 pcs. lockable storage cabinet | |

Options & Accessories

- | | |
|--|------------------------------------|
| 20. Work light 100W LED | 25. Towing support |
| 21. Headlamp forwards / backwards | 26. Extra lockable storage cabinet |
| 22. Heating element control panel platform | 27. Extra toolbox |
| 23. Heating element control panel chassis | 28. Folding seat for platform |
| 24. Cable drum on stand | 29. Air / water hose platform |



Andre fordeler:

- High driving speed (8 km/h) in lowered position increases efficiency
- 4WD and traction control as standard
- The exclusive Genie® Active Oscillating axle automatically adjusts the axle position according to ground conditions
- Stepless lowering speed eliminates rough motion upon lowering of platform
- LED lighting kit
- Driveable with platform at full working height
- Easy service access to all components

About Hybeko

Hybeko is a nationwide machine dealer with access and lifting equipment as a special field. Hybeko produce, imports and sell access and lifting equipment. The company was established in 1972 and has 52 employees. Hybeko has its head office in Skien and branch offices in Bergen, Trondheim and Lillestrøm. The company has a nationwide service network and an extensive parts inventory. Hybeko is certified through NEMKO and performs certified annual inspections.



HYBEKO

www.hybeko.no

Main office visiting address:
Bøleveien 212, 3713 Skien, Norway
Phone: +47 35 50 85 00
E-mail: post@hybeko.no